



FireBob 69

Installation and Operating Instructions.



CONTENTS

About your stove	3
Building regulations	4
Ventilation	4
Positioning & clearances	4
Chimney requirements	5
Typical installation	6
Lighting the stove	10
Wood burning tips & general advice	11
Cleaning & maintenance	12
Troubleshooting	13

ABOUT YOUR STOVE

Stove Model	FireBob 69
Approval	EN 13240:2001 DEFRA Smoke control area exemption EcoDesign 2022
Output	5kW
Efficiency	82% net
Flue	6" (150mm)
Fuel	Wood Logs
Weight	60kg (subject to flue length)
Flue Draught for nominal output	12Pa
Flue Temp at nominal output	143 °C
Ventilation with air permeability >5m³/ (h.m²)	None Required
Ventilation with air permeability <5m³/ (h.m²)	27.5cm ²
Clearance to Combustibles	Rear: 150 mm (400mm for flat back version) Sides: 400mm Front: 1000mm Flue: 450mm

DIMENSIONS

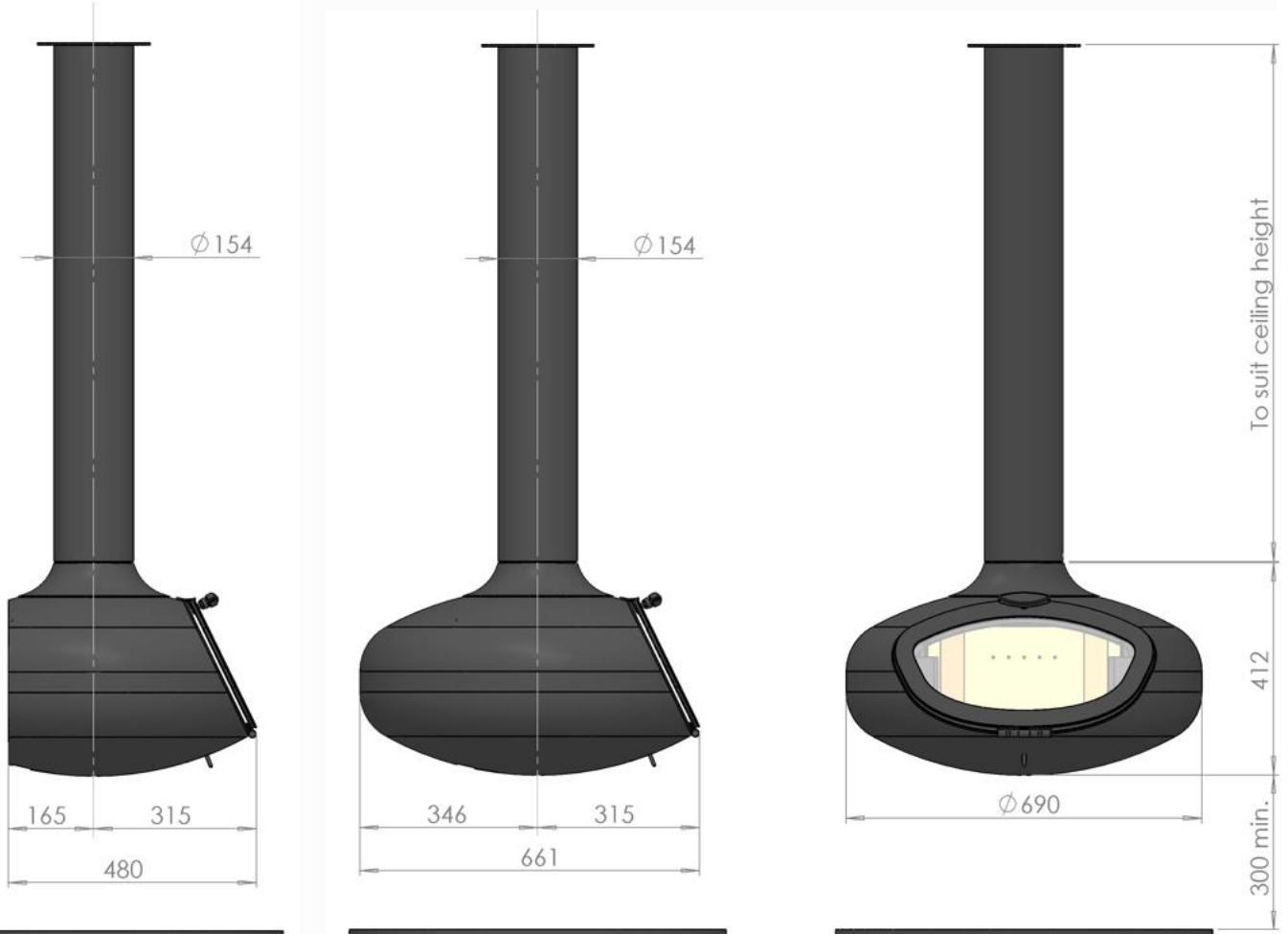

(Flat Back version)

Building regulations

Installation of your stove must comply with all local regulations, including those referring to national and European Standards.

The Clean Air Act 1993 and Smoke Control Areas

Under the Clean Air Act local authorities may declare the whole or part of the district of the authority to be a smoke control area. It is an offence to emit smoke from a chimney of a building, from a furnace or from any fixed boiler if located in a designated smoke control area. It is also an offence to acquire an “unauthorised fuel” for use within a smoke control area unless it is used in an “exempt” appliance (“exempted” from the controls which generally apply in the smoke control area). In England appliances are exempted by publication on a list by the Secretary of State in accordance with changes made to sections 20 and 21 of the Clean Air Act 1993 by section 15 of the Deregulation Act 2015. Similarly, in Scotland appliances are exempted by publication on a list by Scottish Ministers under section 50 of the Regulatory Reform (Scotland) Act 2014. In Wales and Northern Ireland these are authorised by regulations made by Welsh Ministers and by the Department of the Environment respectively. Further information on the requirements of the Clean Air Act can be found here at: <https://www.gov.uk/smoke-control-area-rules> Your local authority is responsible for implementing the Clean Air Act 1993 including designation and supervision of smoke control areas and you can contact them for details of Clean Air Act requirements.

The FireBob 69 has been recommended as suitable for use in smoke control areas when burning wood logs. The appliance must be fitted with a permanent stop to prevent closure of the secondary air control beyond 10% open.

Installation

In the UK installation can be carried out by any competent person, provided the installation is carried out to Building Regulations and checked and signed-off by a local council building inspector. Alternatively, you can use a member of a certified installation body, such as HETAS, which will negate the involvement of the local council building inspector.

Ventilation

The stove requires an air supply for combustion. This can be supplied by an airbrick with a permanently open area. Any airbricks or grilles fitted should be positioned so that they are not liable to blockage. If other appliances requiring ventilation operate within the vicinity of the stove there must be adequate ventilation provided for both appliances running simultaneously.

Note: Extractor fans when operating in the same room or space as the stove may cause problems.

Hearth

The stove should be installed above a non-combustible hearth. The hearth should extend to 225mm in front of the stove and 150mm to each side. A 12mm thick non-structural hearth can be used.

Positioning & clearances

The minimum clearance between the stove and combustible materials is:

Rear 150mm (400mm for the flat back version)

Sides 400mm

Front 1000mm

The minimum clearance between the flue and combustible materials is 450mm.

A minimum clearance of 50mm should be left between the stove and non-combustible materials.

Carbon monoxide alarm

An approved carbon monoxide alarm with a seven-year life sealed battery must be installed when any solid fuel appliance is installed. Carbon monoxide alarms need to meet European safety standards and must be audible. They must be fitted in accordance with the manufacturer’s instructions. An alarm is not a substitute for regular maintenance and chimney sweeping.

Flue/Chimney

The minimum flue draught required for nominal heat output is 12 Pascals. The appliance should not be connected to a shared flue.

The stove is typically installed using a 6" twin wall flue system. See '**Typical Installation**' below.

Alternatively, the stove can be fitted to an existing masonry chimney. The chimney should be given a visual inspection to check that it is in good order, clear of obstructions and is of suitable size and type for the stove. It may be necessary to sweep the chimney. This should be done prior to fitting the stove or lining the chimney. We also recommend a smoke test to check for gas tightness and chimney draft. We recommend lining and insulating your chimney.

Typical Installation



This shows a typical pitched roof installation.

Flat roof installation is the same.

Please contact us if you'd like to discuss variations on the install.

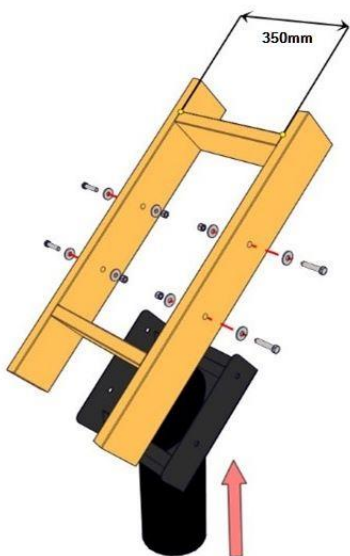

Ceiling Bracket

Fix the custom-made bracket to your ceiling joists/rafters/trusses (we will make a bracket to suit your roof timbers or steel structure).

Structure

Depending on the flue length the stove will weigh approximately 60kg. It is advised to consult a structural engineer to confirm the roof structure is adequate.



Ceiling Bracket

Plumb the bracket to make sure it is vertical.

Once the bracket is in place then the ceiling can be plastered around the bracket if required.



External flue

Attach a single wall adapter to the bottom of the first length of twin wall pipe and drop down into the socket. Make sure the adapter fits into the ring at the bottom of the bracket.

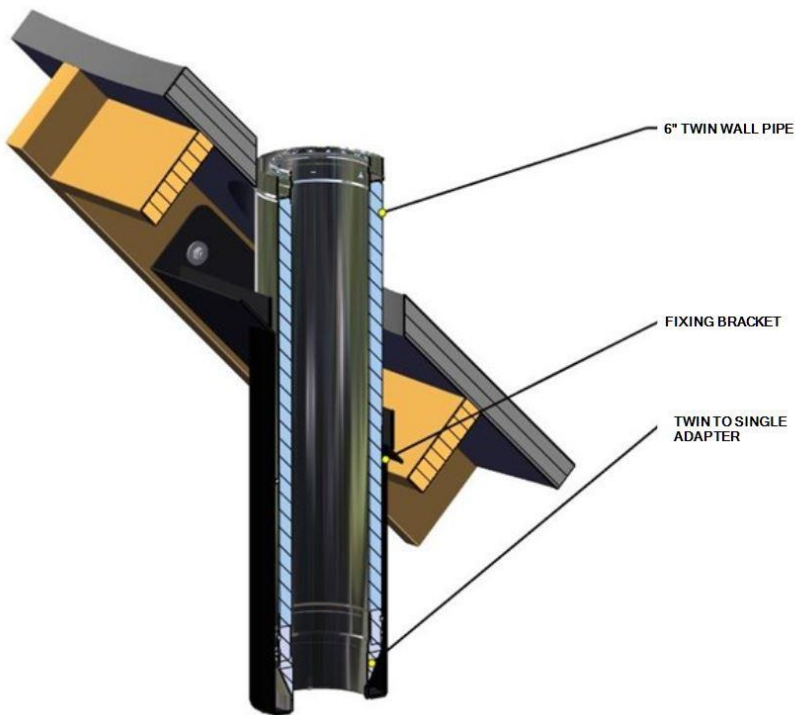

External flue

The flue is 6" insulated twin wall pipe. Available from Firemaker or any flue supplier.

Polished stainless steel as standard but also available in powder coated RAL colours.



External flue

The roof flashing and the rest of the external flue parts can now be fitted.

Check local building regulations to determine height of flue required.

(Google 'building regs document J' for UK).
Page 26 on the PDF.



Internal flue

The internal flue comes in one piece (up to 6m long) to suit your ceiling height.

This is attached to the ceiling bracket with the eight M8 bolts provided.

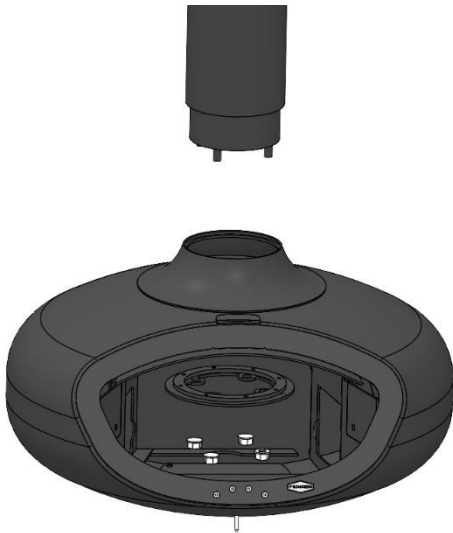

Fire Connection

If the fire and flue are not connected on delivery then fix as shown with the 4 x M12 nuts.

The firebricks and baffle will need to be removed to gain access.

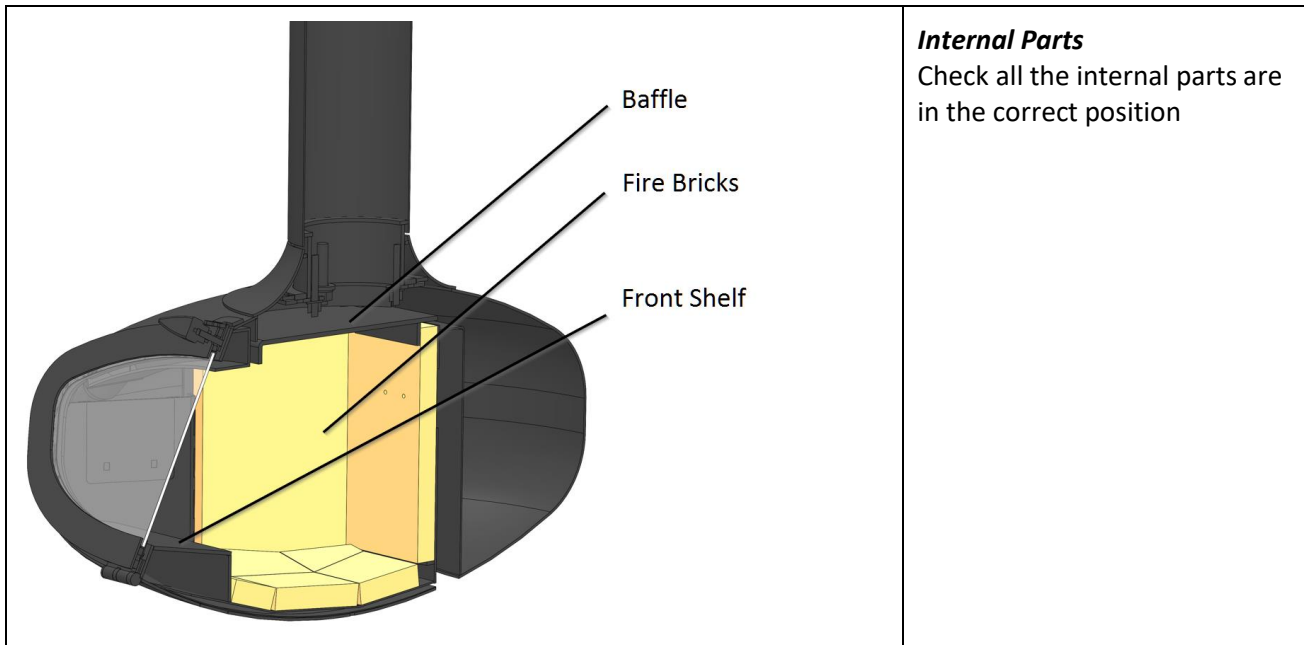

Lighting the stove

Before lighting the stove ensure all firebrick linings and other internal components are in position and that all packaging has been removed. Check that all the flue-ways are clear especially if the stove has not been used for a long time.

If lighting your stove for the first time it should not be stoked excessively as all materials must be given time to adapt to the effects of heat. Curing of the high temperature paint finish will occur and a smell will be evident. Ventilate the room by opening windows. All parts of the stove become hot after a while. Use a glove when operating the door handle and air control.

Step 1 Open the air control fully (see image below).

Step 2 Place tightly crumpled newspaper or a fire-lighter at the centre of the firebed. Place small kindling on top of the newspaper and then a few larger pieces of wood on top of this. Light the newspaper and rest the door on the latch so that the door is open slightly. **NEVER USE FLAMMABLE LIQUIDS TO LIGHT YOUR STOVE.**

Step 3 Allow the fire to burn until all the pieces of wood are alight and burning. More and larger pieces of wood can now be added.

Step 4 Once the fire is established latch the door so that it is fully closed. The air control lever can be moved towards the 'cold' setting to maintain a steady burn rate. The stove will burn approximately 1.1kg of dry logs every 45 minutes to give an output of around 5kW with the air setting 20% open.

Notes:

- Do not run the stove with the door open.
- This stove is designed for intermittent and not continuous operation.

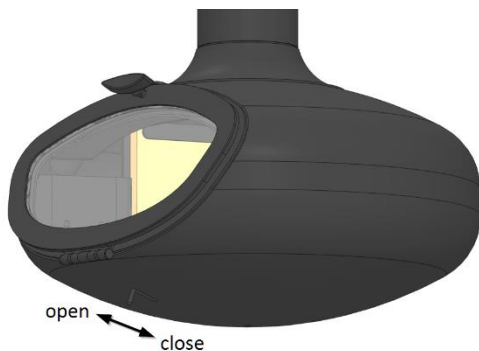

Air control lever shown in the open 'hot' setting.

Glass Window

The stove has an 'airwash' system to help keep the glass clear of soot. Burning small hot fires instead of large slumbering ones will help keep the glass clean. Some build up will occur over time and this can be removed using stove glass cleaner. Vitcas stove glass cleaner works well.

Wood burning tips and theory

The first stage of the fire, just after lighting, is usually the smokiest because the cold wood and cold stove take heat away from the flames. During this stage ensure the air inlet is fully open to increase the flame temperature. It may appear that this initial hot burn allows too much heat straight into the flue system however this is a necessary part of an efficient fire. The additional heat primes the chimney to produce a strong draft and helps keep the chimney/flue clean by loosening creosote deposits that may have been deposited by a previous fire. The hot initial burn also drives moisture from the firewood and gives an ignition source for the smoke that is released from the wood.

Do not try to add too much fuel at once. Adding fuel gradually will help maintain a steady temperature and burning rate so that the stove burns efficiently and cleanly. Adding too much fuel at once will dramatically reduce the temperature inside the firebox.

This also applies to the air control. Adjusting it gradually will help maintain a steady combustion rate. In most instances, you will arrive at the best combustion air settings yourself, as the height and diameter of the chimney as well as the quality of the firewood are decisive factors in determining how your stove is best set.

Small, hot fires are more efficient than large slumbering fires. Most of the energy in burning wood is released as a bright flame. The flame mixes the combustion air and the gases that are released from the wood as it heats up. The heat of the fire ignites and burns these gases. In contrast, the dense smoke from a slow, smouldering fire is potential heat energy that escapes up the chimney and either clings to the chimney flue as creosote or pollutes the atmosphere. To gain the most heat from each burn the wood should be flaming throughout the burn cycle until it is reduced to ash.

When refuelling, place two logs 200mm long totalling 1.1kg onto the firebed as shown for the best combustion.

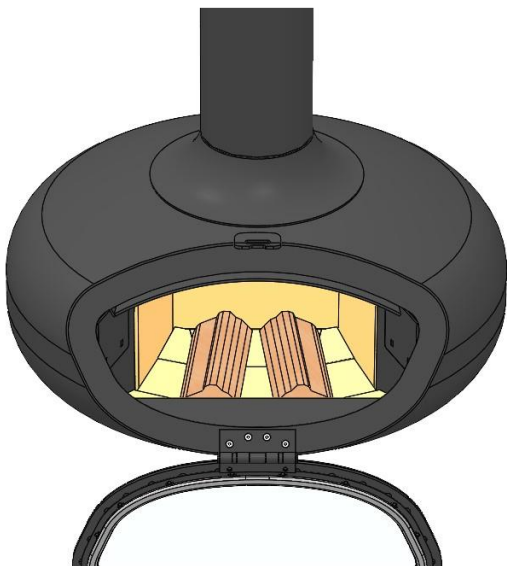

Over Heating

Should the stove get too hot and is overheating, move the air control lever to the 'cold' setting. Keep the fire door closed and allow the fire to burn down.

Fire Prevention

Make sure furniture, curtains, firewood, or any other combustibles are kept clear of the fire and the flue pipe. Observe the clearance to combustibles distances given on Page 3.

Chimney fire

In the event of a chimney fire dial 999 and ask for the Fire Service. Move the air control lever to the 'cold' setting and keep the stove door closed. Move any combustibles away from the stove and chimney. Check any other rooms that the chimney or flue passes through and move any combustibles away from the chimney. Before using the stove again after a chimney fire, the chimney should be cleaned and inspected by a qualified person.

Types of fuel

Wood needs to be well seasoned before it is burned. There are many types of wood available for fuel and they take varying amounts of time to season. As a general guide wood should be cut to length, split, and then stacked under cover with sides open to air for at least twelve months. Wood is ready for burning when radial cracks appear in the end of the logs and moisture content is no more than 20%. It is then good practice to store the wood in a log basket inside your property for a few days prior to its use. Do not burn unseasoned wood in your stove. Do not burn particle board, lacquered, painted, or treated wood, plastics, rubber or liquid fuels.

The FireBob 69 has been recommended as suitable for use in smoke control areas when burning wood logs. The wood should have a moisture content of no more than 20%. The recommended split log size is 200mm x 70mm x 70mm and the maximum recommended burn rate is 1.2kg of wood per hour with a maximum fuel load of 1.1kg at any one time.

Refuelling on to a low fire bed

If there is insufficient burning material in the fire bed to light a new fuel charge, excessive smoke emission can occur. Refuelling must be carried out onto enough glowing embers and ash that the new fuel charge will ignite in a reasonable period. If there are too few embers in the fire bed, add suitable kindling to prevent excessive smoke.

Fuel overloading

The maximum amount of fuel specified in this manual should not be exceeded, overloading can cause excess smoke.

Ashes

The ashes should only be removed when the fire is extinguished and has been left to cool completely.

Cleaning & maintenance

Maintenance of the stove should only be carried out by a competent engineer when the stove is cold. These checks should include the state of the rope seals, firebricks, and baffle. The exterior of the fire can be cleaned with a soft brush. Never use spirits to clean the stove as this may remove the paint.

Seasonal use

The following procedure should be followed if the stove is not to be used for a long period, summertime for instance. Remove all the ashes from the firebox. Remove the baffle plate and brush the flue ways. Close the door and open the air control fully. This action will allow air circulation through the flue ways and help avoid corrosion and condensation.

Flue draught Issues

Adverse weather conditions may result in either too little or too much flue draught. Excessive flue draught may cause the fire to burn on a high rate whilst too little draught or 'down draught' may cause the fire to burn too slowly, extinguish the fire or even force smoke into the room. In either case, allow the fire to go out and do not use until you have consulted an installer to help improve the performance of the chimney.

Chimney sweeping

The chimney should be swept a minimum of once per year. Your stove should also be given a visual inspection every time the chimney is swept. Any build-up of soot and ashes within the stove should be removed. Sweeping can be carried out through the stove by removing the steel baffle. The steel baffle is held in place by the firebricks so carefully remove these first.

Fire bricks

The fire bricks are manufactured from vermiculite. Vermiculite is a non-combustible, fire-resistant board with excellent thermal insulation properties. Position logs gently when refuelling to prevent damage to the firebricks. Over time the firebricks may crack but only need replacing if they become worn through.

Glass

Wipe the glass after each fire and once the stove has cooled completely to prevent any build-up of deposits. This is best done using a paper towel or newspaper to avoid scratching the glass.

If the glass is blackened by soot, it can be easily cleaned using a specialist stove glass cleaning product.

Paint Finish

The high temperature paint finish should require no further treatment though small areas can be touched up if damaged. An aerosol of colour-matched heat-resistant paint is included. Shake the can very well. Practice using the spray can on a scrap piece of cardboard before applying to the stove. Spray lightly from around 20cm distance in thin coats. Allow to dry between coats. Three thin coats are usually enough.

Note: Do not modify the fire and only use replacement parts as specified by Firemaker Ltd.

TROUBLE SHOOTING

Blackened glass

Possible causes include the wood being too damp. Use only wood that has been stored for at least twelve months under cover and with a moisture content less than 20%. Make sure the fire is run with the air control fully open and that there is sufficient ventilation to provide air for combustion. A poor chimney draught will result in a lack of air into the fire and poor combustion. Ensure the stove is run at high enough temperature to burn the wood smoke.

Smoke in the room when refuelling

Avoid opening the door when there are high flames or fresh fuel on the fire. Open the door slowly to avoid 'pulling' the smoke into the room. Poor flue draught will result in a smoky fire. Talk to an installer about improving the flue draught. Remedies for a low draught may include increasing the flue height, changing the flue cowl, and insulating the chimney.

Uncontrollable combustion

This may be caused by a strong chimney draft and excess air being drawn into the stove. Check to see that the door rope seal is in good order and that the air control can be closed.